

Advance
by Technology ...



Sophisticated engineering leads to unreached flexibility and performance.

Our customers's process demand solutions beyond the tablet press. Therefore Pharma Flex offers peripheral devices as integrated solutions, which provides great customer benefits. As always, this new generation of vertical dedusters has been developed to achieve the highest possible flexibility, in conjunction with superior figures for output and quality of dedusting.

PHARMA FLEX

TABLETS DEDUSTER
& METAL DETECTOR

PHARMA FLEX

OEL 5 Smepac tested



PATENT
PENDING

Containment & washable features



Advantages :

- ✓ New dedusting - deburring technology
- ✓ Height flexibility due to modular segments
- ✓ FDA approved robust segments
- ✓ Very low noise level < 60 dba
- ✓ Fast product change over due to Exchangeable Deduster Modul «EDM» < 2 min.
- ✓ Reduced cleaning time & full parts inspection
- ✓ Containment «C» capabilities
- ✓ Upgrade to High-Containment «HC» & Washable
- ✓ Higher throughput - capacity
- ✓ Complete emptying at the end of the batch with any shape of tablet or capsule

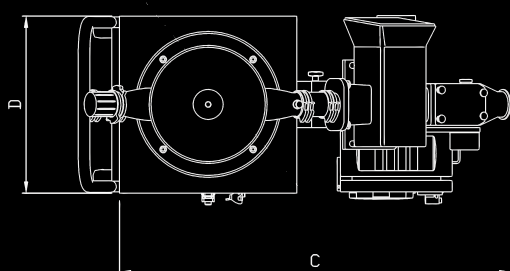
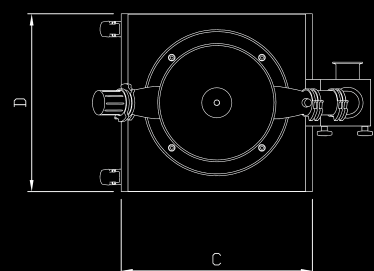
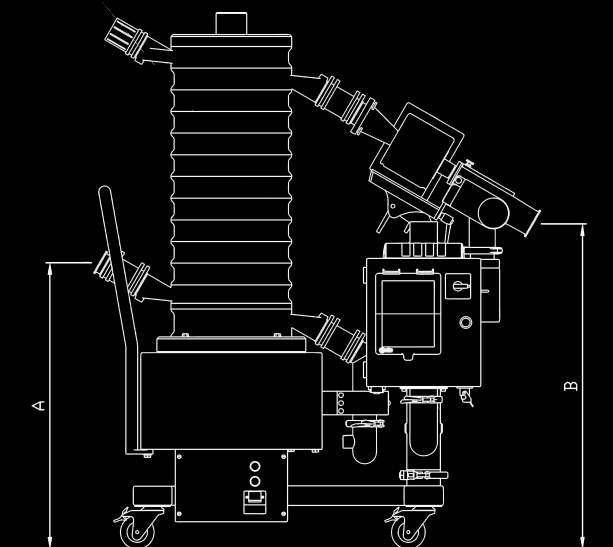
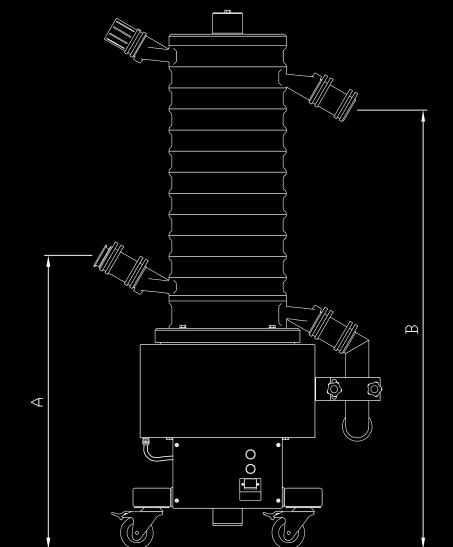

Technical data :	500		750		1000		1200	
Inlet height (A)	730 mm - 820 mm		730 mm - 820 mm		730 mm - 820 mm		730 mm - 820 mm	
Outlet height (B) without detector	Inlet height (A) + 380 mm		Inlet height (A) + 655 mm		Inlet height (A) + 930 mm		Inlet height (A) + 1095 mm	
Outlet height (B) Ceia	Inlet height (A) + 95 mm		Inlet height (A) + 370 mm		Inlet height (A) + 645 mm		Inlet height (A) + 810 mm	
Outlet height (B) Lock	Inlet height (A) + 60 mm		Inlet height (A) + 335 mm		Inlet height (A) + 610 mm		Inlet height (A) + 775 mm	
Floor dimensions (Cx D)	790 mm x 460 mm		790 mm x 460 mm		790 mm x 460 mm		790 mm x 460 mm	
Inlet chute	DN50 adapter		DN50 adapter		DN50 adapter		DN50 adapter	
Outlet chute	Ø ISO 50		Ø ISO 50		Ø ISO 50		Ø ISO 50	
Minimum product size	Ø 3 mm		Ø 3 mm		Ø 3 mm		Ø 3 mm	
Maximum product size	Ø 25 mm		Ø 25 mm		Ø 25 mm		Ø 25 mm	
Conveying adjustment	Frequency / Voltage		Frequency / Voltage		Frequency / Voltage		Frequency / Voltage	
Conveying time	40 sec.		80 sec.		110 sec.		140 sec.	
Self emptying	Yes		Yes		Yes		Yes	
Requested vacuum	180 m³/h - 2000Pa		180 m³/h - 2000Pa		180 m³/h - 2000Pa		180 m³/h - 2000Pa	
Vacuum connection	Ø ISO 50		Ø ISO 50		Ø ISO 50		Ø ISO 50	
Requested compressed air	80L/min - min.3bar		80L/min - min.3bar		80L/min - min.3bar		80L/min - min.3bar	
Compressed air connection	QS6		QS6		QS6		QS6	
Noise level (with product)	60 to 65 dbA		60 to 65 dbA		60 to 65 dbA		60 to 65 dbA	
Power supply	110V or 230V		111V or 230V		112V or 230V		113V or 230V	
Frequency	50 Hz or 60 Hz		50 Hz or 60 Hz		50 Hz or 60 Hz		50 Hz or 60 Hz	
FDA material	Celanex 2404 MT		Celanex 2404 MT		Celanex 2404 MT		Celanex 2404 MT	
Roughness	RA < 0,5 µm		RA < 0,5 µm		RA < 0,5 µm		RA < 0,5 µm	
Frame parts	Stainless steel 304		Stainless steel 304		Stainless steel 304		Stainless steel 304	
Frame finishing	Mirror polished		Mirror polished		Mirror polished		Mirror polished	
Frame mounted on wheels	Yes		Yes		Yes		Yes	
IQ-OQ protocol	Available		Available		Available		Available	
Material certificates	Available		Available		Available		Available	
Packing	Box on 1 US pallet		Box on 1 US pallet		Box on 1 US pallet		Box on 1 US pallet	
Net weight	140 Kg		155 Kg		170 Kg		185 Kg	
Gross weight	190 Kg		205 Kg		230 Kg		235 Kg	
Metal detector :	Ceia	Lock	Ceia	Lock	Ceia	Lock	Ceia	Lock
Accuracy stainless steel	0,50 mm	0,50 mm	0,50 mm	0,50 mm	0,50 mm	0,50 mm	0,50 mm	0,50 mm
Accuracy non-ferro	0,35 mm	0,50 mm	0,35 mm	0,50 mm	0,35 mm	0,50 mm	0,35 mm	0,50 mm
Accuracy ferro	0,30 mm	0,30 mm	0,30 mm	0,30 mm	0,30 mm	0,30 mm	0,30 mm	0,30 mm
Capacity / Speed exemples :	tablets / hour		tablets / hour		tablets / hour		tablets / hour	
Round tablets Ø 5 mm	5 200 000		5 200 000		5 200 000		5 200 000	
Round tablets Ø 8 mm	2 800 000		2 800 000		2 800 000		2 800 000	
Round tablets Ø 13 mm	1 000 000		1 000 000		1 000 000		1 000 000	
Shaped tablets 10mm x 4mm	2 500 000		2 500 000		2 500 000		2 500 000	
Shaped tablets 16mm x 6mm	600 000		600 000		600 000		600 000	

Power
Dynamism
Efficiency

Containment
Standard in every Pharma Flex

Progressive design
from containment to washable

More speed
Less noise
With advanced technology, we can do both



← PHARMA FLEX →

Rue de la Maîtrise 11
B-1400 Nivelles
Belgium

Tel: +32 67 64 55 00 - Fax: +32 67 64 55 11
E-Mail: info@pharmatec.be - Web site: www.pharmatec.be